

Torch Height Controller SH-HC31 Manual

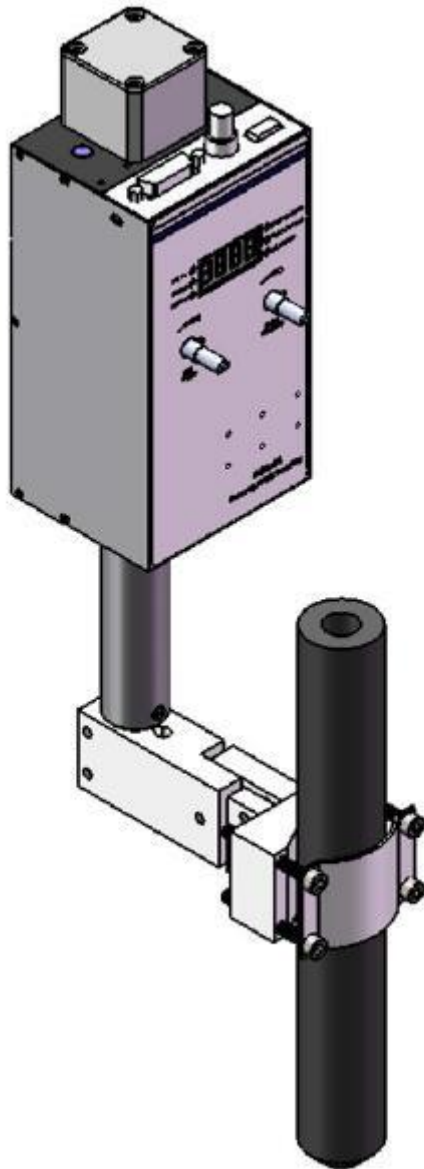

Beijing Flourishing Start Control Technology Co., Ltd.

Tel: 0086 10 8890 9235

Mobile (WhatsApp): 0086 159 0106 9532

Email: cuttingcnc@hotmail.com

Skype: henryhaozq

www.startsh.com

Safety notice

Please carefully read the manual before using the product..

Safety operation

Users must follow safety operation rules made by the country and the company.

Mechanical danger

Operation and repair of automation equipment are a little dangerous and are careful. Please be far away from the working equipment. Please control the equipment by correctly using the panel's buttons. Don't wear so loose clothes when using and repairing the equipment.

High-voltage danger

Be careful of electric shock during operation. Please install the equipment according to its manual. Don't touch cables or wires after power on. Only professional maintenance personal can open the controller. When the equipment has problems, power should be off and then repair.

Power isolation

Please check whether power is right, DC24V before power on.

Good ground-connection

All parts of the cutting machine and the controller should connect ground.

The most effective method of reducing plasma interference is to use shielding wire and good ground-connection. Controller's ground wire diameter should be over 4 mm², and try to keep a shorter distance to the ground. DC24V ground (-) must break with ground.

Controller maintenance

When the controller can't work normally, you need to check relative hardware or wire connection after power off. Don't open the controller to repair without professional personnel. Please feel free to let us know when the controller has problems.

Warranty statement

Guarantee period: within 12 month after leaving our company.

Guarantee terms: during guarantee period any problems under normal operations.

During guarantee period, we charge for out of guarantee terms.

We charge for all problems out of guarantee period.

Following situations are beyond guarantee:

Any damage under abnormal operation or accident damage;

Damaged by plug in and out of the controller when power on;

Natural disasters;

Repair, disassemble, retrofit, etc. at random without our allowance.

Chapter 1 General Introduction

1-1 basic index

Processor: industrial ARM chip

Display: 4-digit nixie tube

Max. stroke: 100mm

Auto height adjustment range: 2-30mm

Height adjustment accuracy: $\pm 0.5\text{mm}$

Auto height adjustment speed: 3000mm/min (max.)

Communication: 485*1

Power supply: DC24V, 3A

Working temperature: $0^{\circ}\text{C} \sim +40^{\circ}\text{C}$

Storage temperature: $-40^{\circ}\text{C} \sim +60^{\circ}\text{C}$

1-2 technical feature

SH-HC31 is the upgrade model of SH-HC30. Besides previous advantages of “integration of

control and mechanical parts”, “stepper motor & driver” and “one-key calibration”, it adds new features as below,

Knobs for height and sensitivity adjustment: it can statically and dynamically adjust the height and the sensitivity and save the result. The pulse adjustment knob has better lifetime and reliability than contact-type potentiometer.

Industrial ARM processor: all new ARM embedded core replaces the previous the single chip. The processing speed is faster and anti-interference ability is stronger.

1-3 installation

Plasma (arc voltage)

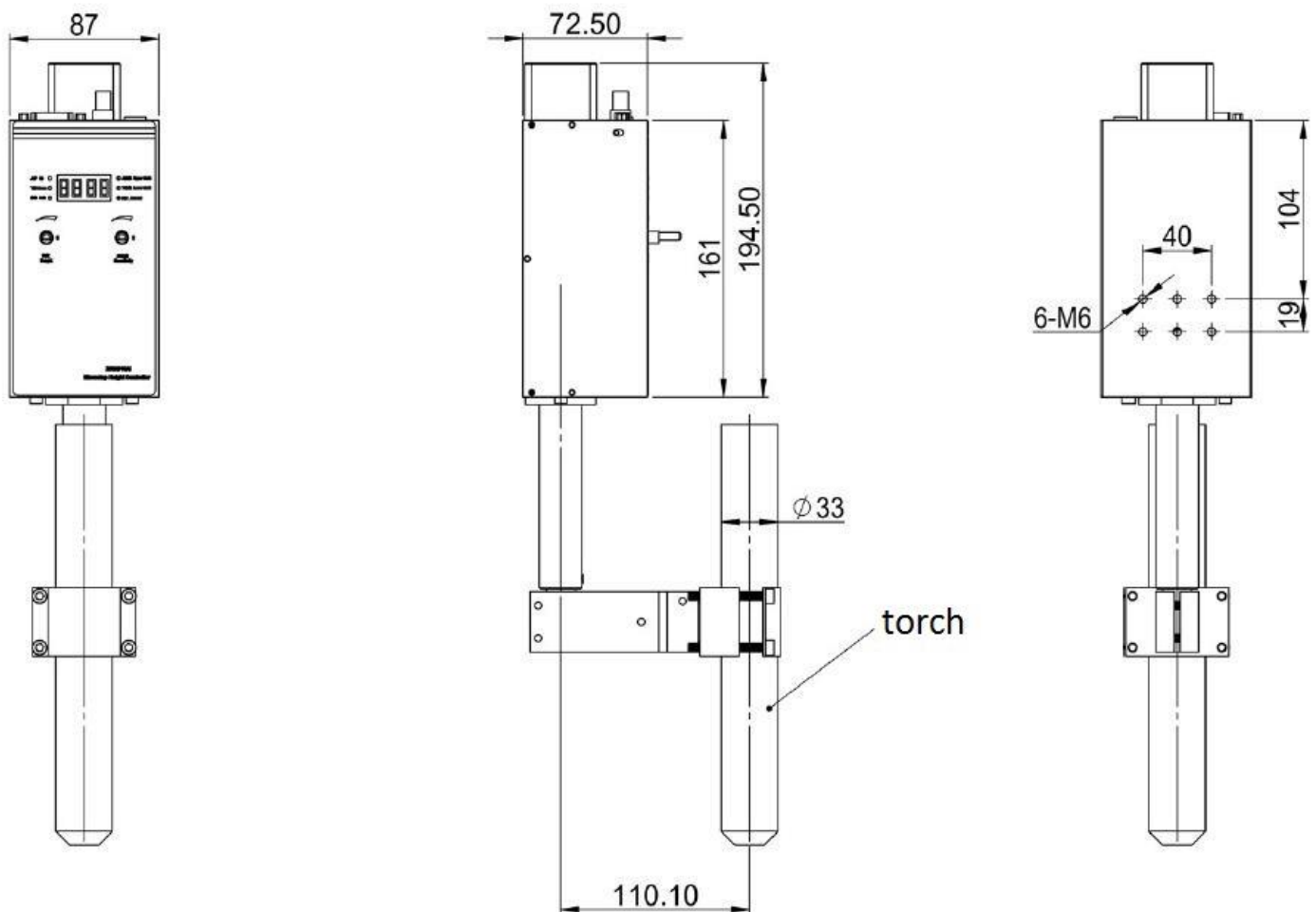

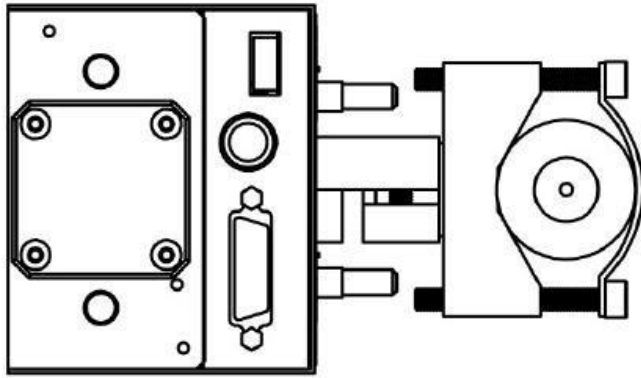

torch diameter $\leq 34\text{mm}$
 installation thread M6
 installation dimension is the same as model SH-HC30

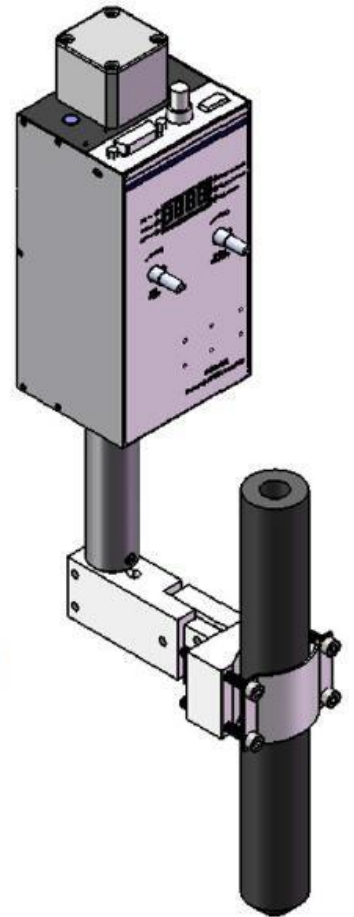

1-4 connection

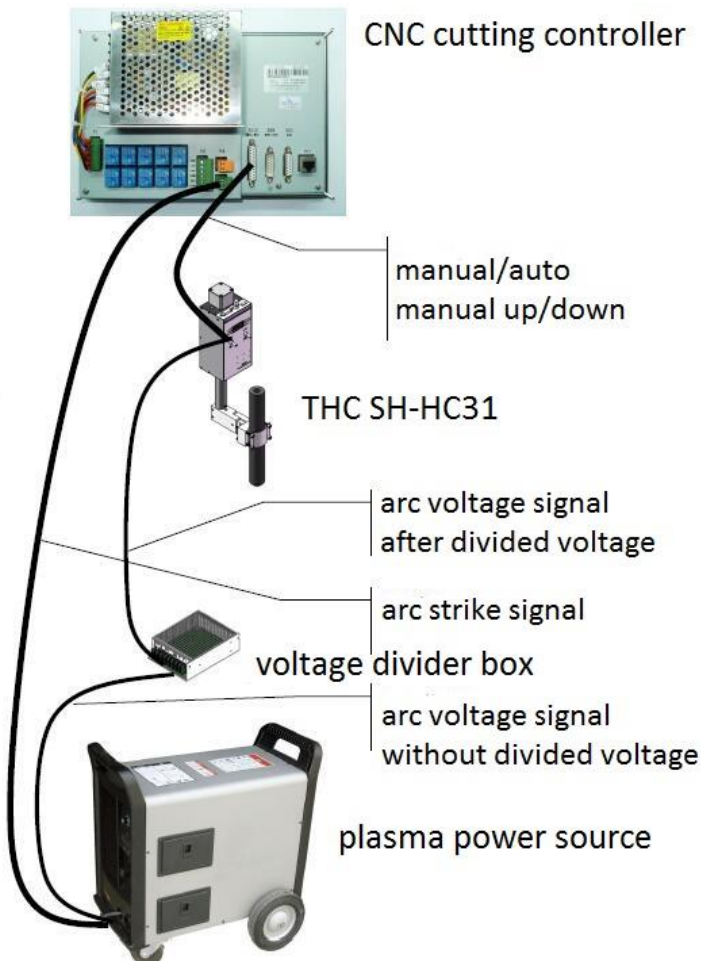

SH-HC31 15-pin port definition

Pin No.	Definition	Instruction
4	Arc voltage signal	Connect arc voltage signal of plasma, input range DC0-5V, if plasma has that, then connect a voltage divider box.
5	Arc voltage signal ground	Connect arc voltage signal ground of plasma
7, 14	DC24V+	Connect DC24V+
8, 15	DC24VG	Connect DC24VG
10	Manual/auto	Connect CNC output or external switch, 24V signal, high level is manual, low level is auto.
11	Plasma/flame	Connect CNC output or external switch, 24V signal, high level is plasma, low level is flame.
12	Up	Connect CNC output or external switch, 24V signal, low level is effective
13	down	Connect CNC output or external switch, 24V signal, low level is effective

The connection of SH-HC31 and CNC CC-S3 (S3A), plasma cutting

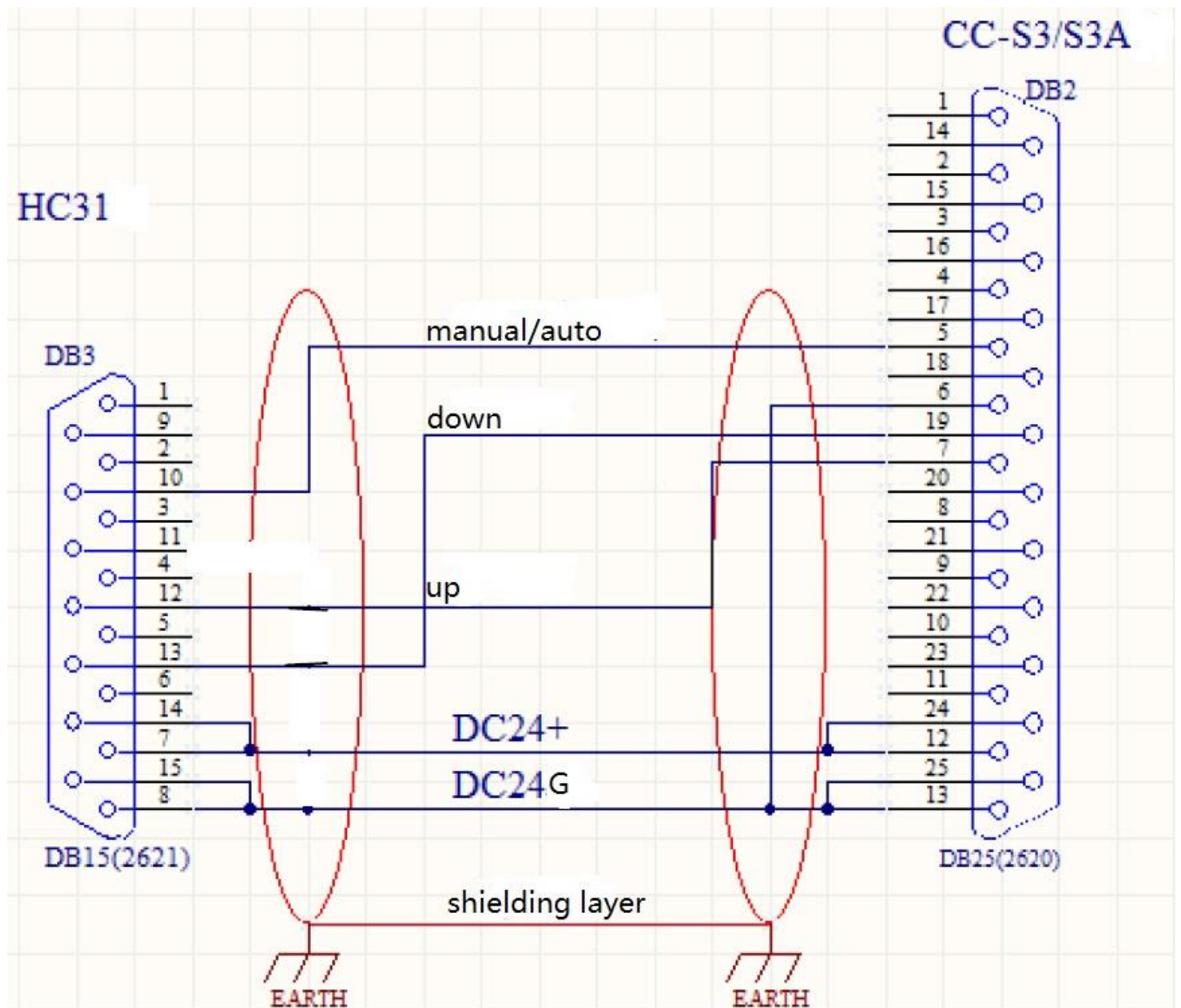

The connection of SH-HC31 and the voltage divider box (plasma cutting)

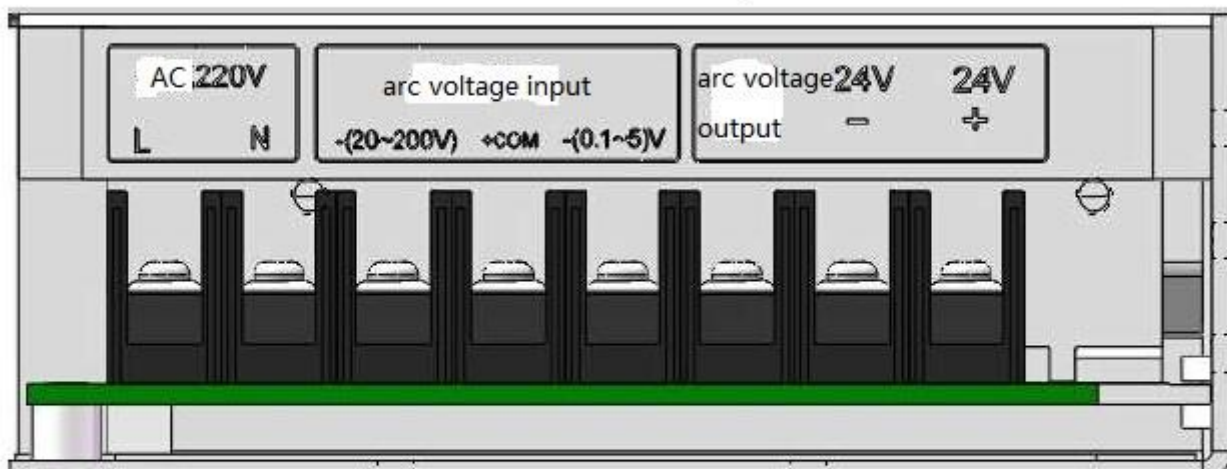
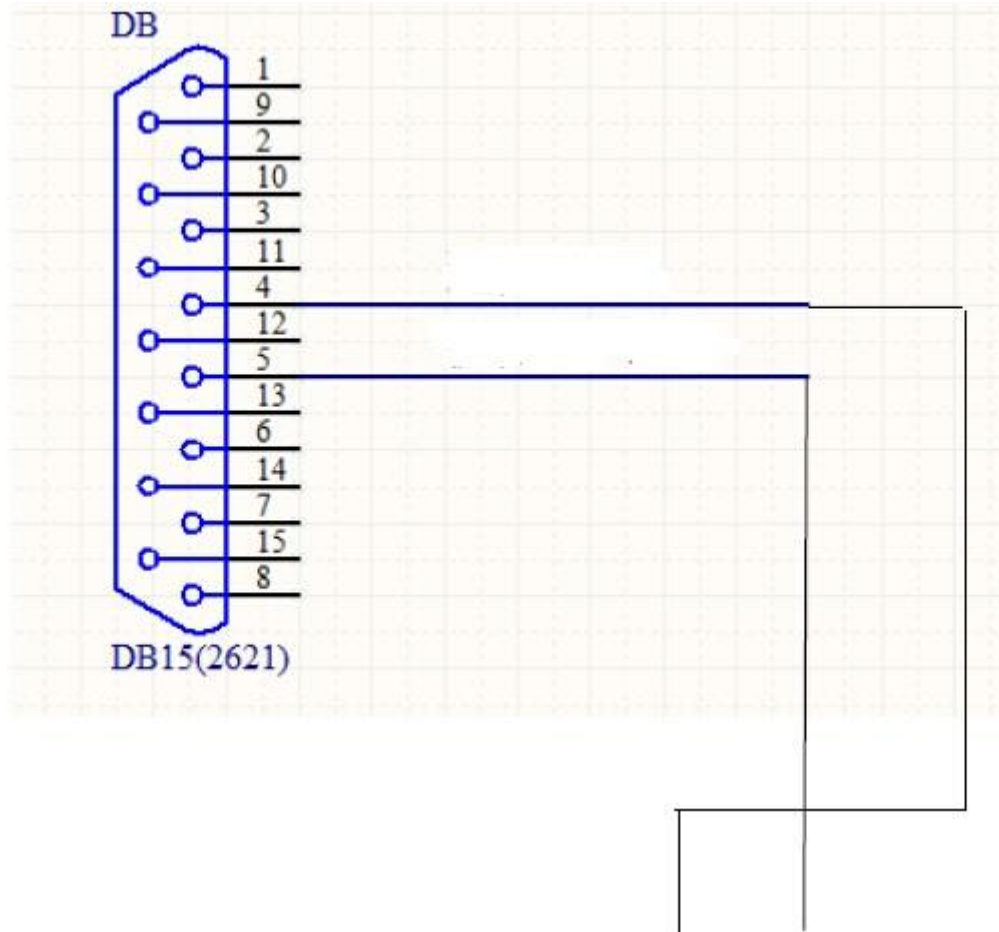

power supply connect plasma source connect DC24V power

Note: if plasma power source is 1:1, then connect $-(20\sim 200)V$ input.

If plasma power source is 50:1, then connect $-(0.1\sim 5)V$. And open the voltage divider box, break the jumper JP2 and connect JP1.

Chapter 2 Quick Start

2-1 panel



Instruction



Height knob, adjust and set the height.

In the plasma mode and the manual mode, press it to show b value (location height), this moment to rotate it to set the location height.



Sensitivity knob, adjust and set the sensitivity.

In the plasma mode and the manual mode, press it for one-button location, the torch moves down, and touches the zero point switch, and then moves up to the location height and stops.

In the flame mode and the manual mode, press it 2s for one-button calibration.



LED screen, display settings and working information



Indicator lights, display working states

2-2 plasma mode

Quick start procedure

Power on it, choose the plasma mode → press the sensitivity button for the initial location (and press the height button to adjust b value) → manually cut a line to check the arc voltage value in LED screen → set that arc voltage value for auto height → start auto cutting to check the height (adjust the arc voltage height and sensitivity) → finish setting.

2-3 display and state

LED display

U: plasma mode, range 30~250

C: flame mode, range 30~300

E: sensitivity, range 1~10

b: initial location height, range 1~20mm

Indicator lights

Up: move up

Down: move down

Auto: in the auto mode. When the light off, in the manual mode

Upper limit

Lower limit

Arc voltage: there is arc voltage signal input

2-4 error tip

EE01: cancel auto, press the sensitivity button to cancel the error

EE02: setting save fails, power on again